

# KENIA-90D VISON



SCL



SSV



19



66



5,5



475



145



200



2x120



2x160



760x270x450



72



M-19, M-20 M-27 M-28

## Traits

- Système Vitre Propre
- Système de Sécurité dans les Ventilateurs
- La puissance de chauffage: 19kw
- Rendement (%): 66%
- Consommation(kg/h): 5,5kg/h
- Volume chauffé (m3): 475m3
- Intérieur en vermiculite
- Fabriqué en tôle
- Poids (kg): 145kg
- Diamètre sortie de fumée (mm): 200mm
- Canalisable (diamètre et nombre de sorties): 2x120
- Ventilation forcée: 2x160
- Système verre propre
- Mesures de l'entrée utile de la chambre: 760x270x450mm
- Taille maximum des troncs: 72cm
- Accessoires compatibles non inclus: M-19, M-20; M-27; M-28

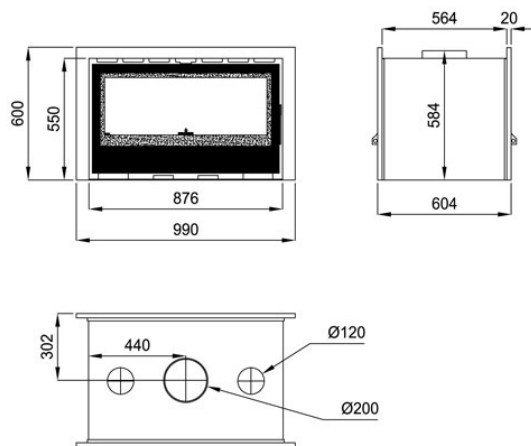

Compte tenu de l'amélioration continue de nos produits et l'amélioration de notre processus de fabrication, de taille, l'esthétique et les spécifications des produits sont sujets à changement sans préavis de notre société.

[www.bronpi.com](http://www.bronpi.com)

