

CORAL NC



15	14-5	88-91	3,1-1,2	150-300	350	18		6-16	155
80	50	2x80	1x430		KIT WIFI	CANALIZATION KIT			

Features

- CANALIZATION KIT OPTIONAL
- Fast On
- Oasys Plus
- Double Chamber System
- Clean Glass System
- Modulation System
- Model designed for easy access to maintenance service
- Model Compatible with Kit Wifi
- Programmable
- Flame anti-return system
- Power max: 15kw
- Power (kW) max-min: 14-5kw
- Efficiency (%): 88-91%
- Consumption max-min (kg/h): 3,1-1,2kg/h
- Power consumption (W): 150-300W
- Heating capacity (m3): 350m3
- Tank capacity (Kg): 18kg
- Cast-iron interior
- Cast-iron burner
- Autonomy (h) (min-max): 6-16h
- Weight (kg): 155kg
- Fume outlet diameter (mm): 80mm
- Air inlet diameter (mm): 50mm
- Forced ventilation: 1x430

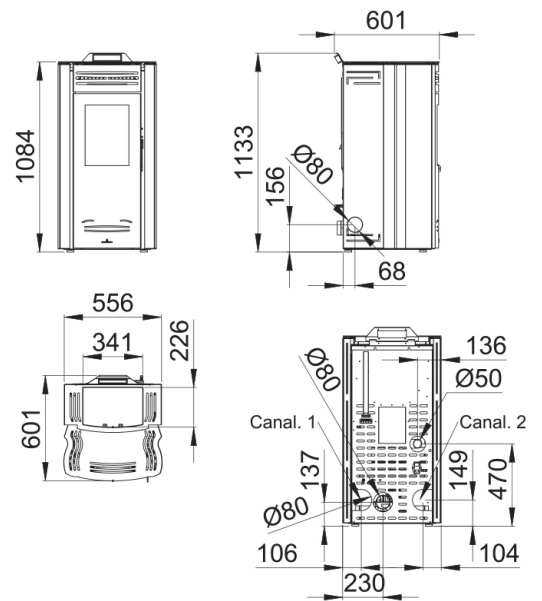

Given the continued improvement of our products and improving our manufacturing process, size, aesthetics and product specifications are subject to change without prior notice from our company.

www.bronpi.com



Features

- Option of side or rear channelling
- Remote control or switchboard
- Hermetic tank
- S1:Security systems: Safety thermostat pellet, Air flow switch
- Compatible accesories not included:KIT WIFI, CANALIZATION KIT