

# KENIA-110D VISION

©Bronpi Calefacción, S.L. reserves all rights to the images that appear in this document. You may not reproduce or distribute part or all of the photographs and as the text. Both the brand as distinctive symbols are the exclusive property of the company. All rights will be prosecuted according to law.



SCL



SSV



23



66



6,1



575



163



250



2x120



4x160



960x265x450



92



M-21 M-22 M-29 M-30

## Features

- Sistema de Cristal Limpio
- Sistema de Seguridad en los Ventiladores
- Potencia calorífica: 23kw
- Rendimiento (%): 66%
- Consumo (kg/h): 6,1kg/h
- Volumen calefactable (m3):575m3
- Interior Vermiculita
- Elaborado en Chapa
- Peso (kg): 163kg
- Diámetro salida de humos (mm): 250mm
- Canalizable (n° x Ø): 2x120
- Ventilación forzada (n° x m3): 4x160
- Boca útil cámara (mm): 960x265x450mm
- Tamaño máx. troncos (cm): 92cm
- Accesorios compatibles no incluidos: M-21; M-22; M-29; M-30

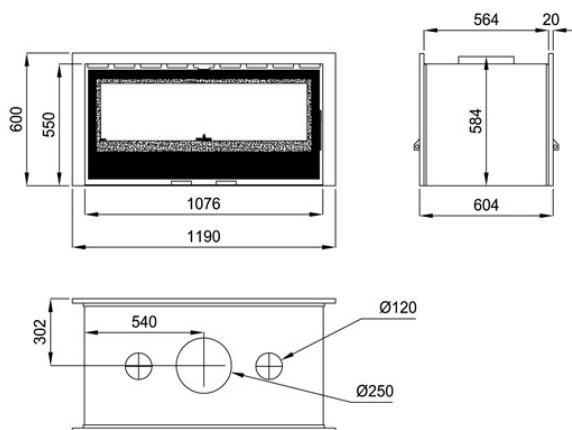

Medida Boca Util: 960 x 265 x 450 mm

Given the continued improvement of our products and improving our manufacturing process, size, aesthetics and product specifications are subject to change without prior notice from our company.

[www.bronpi.com](http://www.bronpi.com)

