







OXFORD

©Bronpi Calefacción, S.L. tiene reservados todos los derechos sobre las imágenes que aparecen en este documento. Está prohibida la reproducción o la difusión parcial o total de las fotografías y así como del texto. Tanto la marca como los símbolos son distintivos propiedad exclusiva de la empresa. Los infractores serán procesados conforme a la ley.



 SDC	 SCL	 SLC								 kW
 4,6	 81	 78	 1,3	 0,75	 115			 51	 150	 275x260x270
 30										

Características

- Sistema de Doble Combustión
- Sistema de Cristal Limpio
- Sistema Multifuel
- Potencia calorífica: 4,6kw
- Potencia carbón: 4,6kw
- Rendimiento (%): 81%
- Rendimiento Carbón (%): 78%
- Consumo (kg/h): 1,3kg/h
- Consumo Carbón (kg/h): 0,75kg/h
- Volumen calefactable (m3): 115m3
- Interior Vermiculita
- Elaborado en fundición y acero
- Peso (kg): 51kg
- Diámetro salida de humos (mm): 150mm
- Boca útil cámara (mm): 275x260x270mm
- Tamaño máx. troncos (cm): 30cm

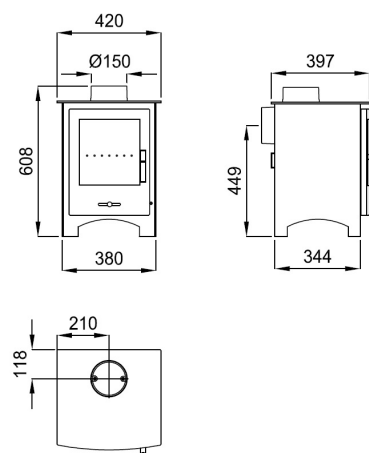

Dada la continua mejora de nuestros productos y el perfeccionamiento de nuestro proceso de fabricación, las dimensiones, la estética del producto y las características técnicas están sujetas a posibles variaciones sin previo aviso por parte de nuestra empresa.

www.bronpi.com

