

CAIRO 110

FACILIDAD DE ACCESO A LA TURBINA DESDE LA CÁMARA DE COMBUSTIÓN.
EASE OF ACCESS TO THE TURBINE FROM THE COMBUSTION CHAMBER.
FACILIDADE DE ACESSO À TURBINA A PARTIR DA CÁMARA DE COMBUSTÃO.
FACILITE D'ACCÈS À TURBINE DEPUIS LA CHAMBRE DE COMBUSTION.
FACILITÀ DI ACCESSO ALLA TURBINA DALLA CAMERA DI COMBUSTIONE.



la excelencia en el fuego



la excelencia en el fuego

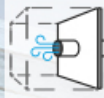

TOMA DE AIRE EXTERIOR - MODELO ESTANCO-
OUTSIDE AIR INTAKE - HERMETIC MODEL-
TOMADA DE AR EXTERIOR - MODELO ESTANQUE-
PRESA D'ARIA EXTERIORE - MODELLO ERMETICO-
PRISE D'AIR EXTERIEURE - MODELE ÉTANCHE-



SDC



SCL



15

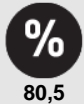

80,5



4,2



375



Kit Vermiculite:170 Kit Ceramic:1290



kg



Ø



2x120



980x260x318



100

Features

- Double Combustion System
- Clean Glass System
- Heating power: 15kw
- Efficiency (%): 80,5%
- Consumption (kg/h): 4,2kg/h
- Heating capacity (m3): 375m3
- Manufactured in cast-iron and steel
- Weight (kg): Kit Vermiculite: 170kg Kit Ceramic: 185kg
- Smoke exit tube diameter (mm): 200mm
- Air channel (diameter and exit tube number): 2x120
- Useful chamber measures: 980x260x318mm
- Maximum logs size (cm): 100cm

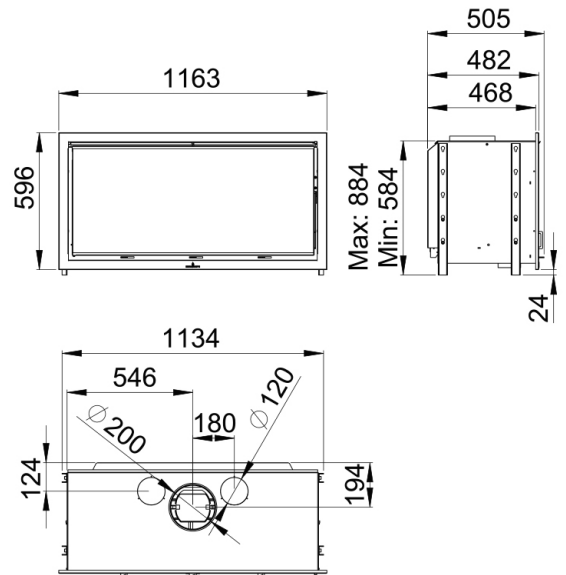

Given the continued improvement of our products and improving our manufacturing process, size, aesthetics and product specifications are subject to change without prior notice from our company.

www.bronpi.com

