

MADRID VISION



SDC



SCL



SSV



19



75



5,06



475



205



200



2x120



2x160



690x330x390



65



M-68 M-69 M-70 M-71

Features

- Double Combustion System
- Clean Glass System
- Security System in Fans
- Heating power: 19kw
- Efficiency (%): 75%
- Consumption (kg/h): 5,06kg/h
- Heating capacity (m3): 475m3
- Cast-iron interior
- Manufactured in cast-iron
- Weight (kg): 205kg
- Smoke exit tube diameter (mm): 200mm
- Air channel (diameter and exit tube number): 2x120
- Forced ventilation: 2x160
- Useful chamber measures: 690x330x390mm
- Maximum logs size (cm): 65cm
- Compatible accesories not included: M-68; M-69; M-70; M-71

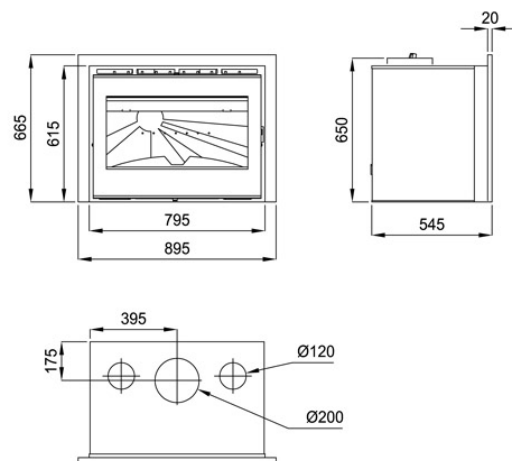

Medida Boca Util: 690 x 330 x 390 mm

Given the continued improvement of our products and improving our manufacturing process, size, aesthetics and product specifications are subject to change without prior notice from our company.

www.bronpi.com

