

EVEREST

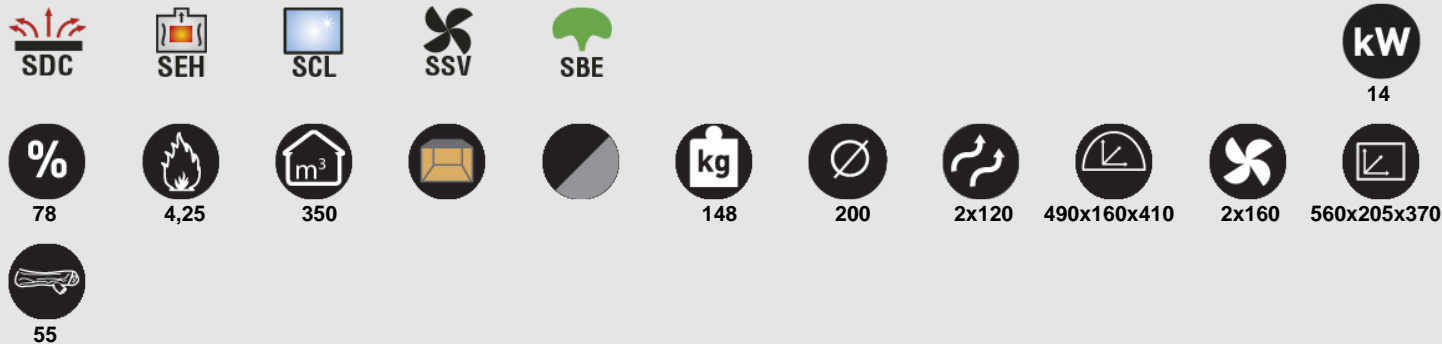

Features

- Double Combustion System
- Surround System Oven
- Clean Glass System
- Security System in Fans
- Low Emissions System
- Heating power: 14kw
- Efficiency (%):78%
- Consumption (kg/h): 4,25kg/h
- Heating capacity (m3):350m3
- Vermiculite inside
- Manufactured in cast-iron and sheet
- Weight (kg): 148kg
- Smoke exit tube diameter (mm): 200mm
- Air channel (diameter and exit tube number): 2x120
- Forced ventilation: 2x160
- Useful chamber measures: 560x205x370mm
- Useful oven measures: 490x160x410mm
- Maximum logs size (cm): 55cm

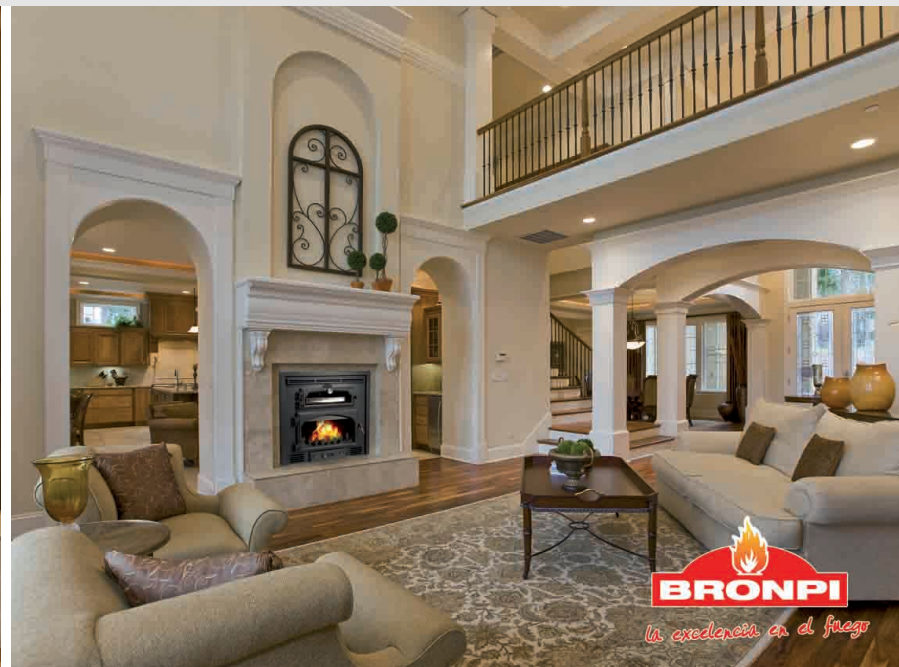
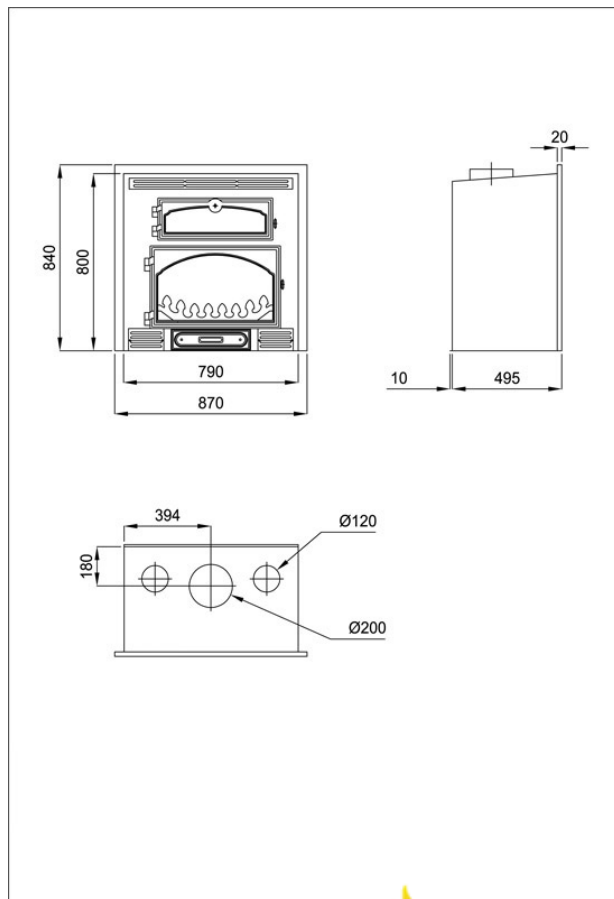

Given the continued improvement of our products and improving our manufacturing process, size, aesthetics and product specifications are subject to change without prior notice from our company.

www.bronpi.com



©Bronpi Calefacción, S.L. reserves all rights to the images that appear in this document. You may not reproduce or distribute part or all of the photographs and as the text. Both the brand as distinctive symbols are the exclusive property of the company. Violators will be prosecuted according to law.