

CANADA RUSTICO

©Bronpi Calefacción, S.L. reserves all rights to the images that appear in this document. You may not reproduce or distribute part or all of the photographs and as the text. Both the brand as distinctive symbols are the exclusive property of the company. Violators will be prosecuted according to law.



SDC



SCL



SSV



kW



71



3,2



325



155



200



2x120



2x160



510x305x280



52



M-3 M-4 M-5 M-6

Features

- Heating power: 13kw
- Efficiency (%): 71%
- Consumption (kg/h): 3,2kg/h
- Heating capacity (m3): 325m3
- Cast-iron inside
- Manufactured in cast-iron
- Weight (kg): 155kg
- Smoke exit tube diameter (mm): 200mm
- Air channel (diameter and exit tube number): 2x120
- Forced ventilation: 2x160
- Useful chamber measures: 510x305x280mm
- Maximum logs size (cm): 52cm
- Compatible accesories not included: M-3; M-4; M-5; M-6

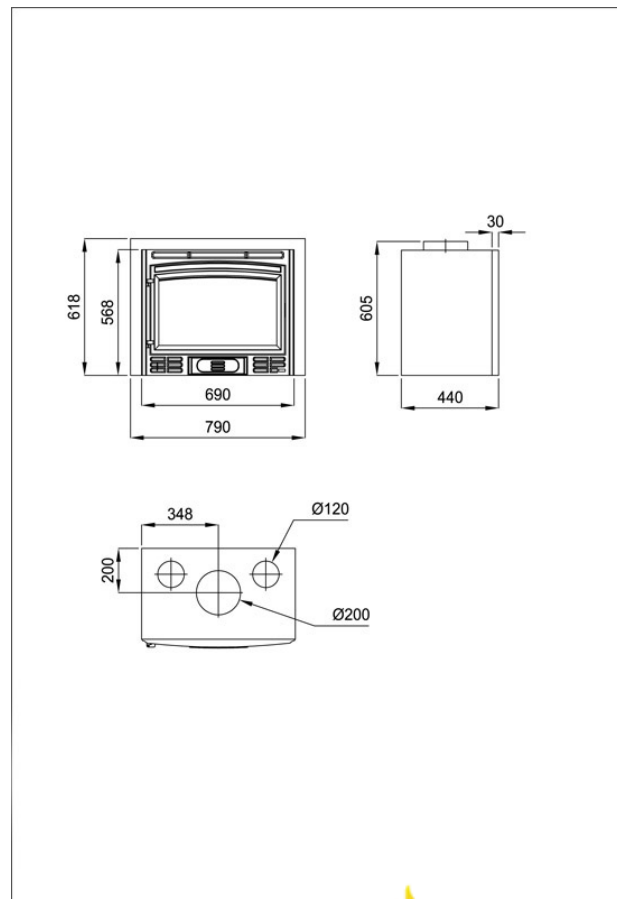

Given the continued improvement of our products and improving our manufacturing process, size, aesthetics and product specifications are subject to change without prior notice from our company.

www.bronpi.com

